



SELTA



SBS-N

**Line traps solution for
PLC communication**

Power Line Carrier (PLC) devices are part of a communication system and are aimed at providing voice and data transmission functions, for example enabling, remote control, teleprotection, telephony which are needed in utilities network infrastructures. SBS-N PLC line traps are used to limit the PLC signals transmission vs undesired networks directions, enabling re-use of power network frequency bands.

DP infrastructures has been designing line traps for more than thirty years gathering a strong know-how and developing high performance devices, compliant with the latest IEC60353 recommendations and offering a wide range of inductances. Current values are therefore available to be used in modern power systems, allowing to cope with higher nominal and short circuit power levels with subsequent very severe mechanical forces in the main coil of the traps.

BENEFITS

- Loss reduction.
- High mechanical strength.
- High short-circuit withstand capability.
- Excellent cooling.
- Light weight.

MAIN FEATURES

 Version available for 800 kV

- High operational reliability thanks to high short circuit current withstand capacity.
- Open structure for optimum cooling of the coil (□ longer life expectancy).
- All components of the main coil carrying the power current -including the H.V. terminals- are weld connected obtaining therefore corrosion free electrical connections.
- A thermal compensation systems allows absorbing the mechanical stresses due to temperature variations.
- Negligible inductance tolerances among identical types for an easier interchangeability.
- High Q for broader usable bandwidth.
- Low self-capacitance of the main coil with subsequent higher resonant frequencies. New tuning units, in case of frequency changes, can be installed without removing the trap or retesting it.
- High pulse withstand of the tuning unit provides high operational reliability.
- The small size reduces the forces acting on coupling capacitors/CVT/post insulators: it is easy to obtain the required clearances between the phases.
- The reduced weight simplifies the installation.
- Bird barriers prevent the intrusion of birds into the main coil. They consist of a temperature and UV resistant reinforced nylon grid.
- No maintenance is required.
- Internal simulator for automations check.

SURGE ARRESTER

One surge arrester is linked in parallel to the terminals of the main coil and to the tuning unit to protect them from transient over voltages. The surge arrester is accessibly mounted inside the main coil and it is located near the tuning unit, to provide optimum protection.

TUNING DEVICE

DP Selta line traps are supplied with parallel connected tuning devices making the attenuation and impedance characteristics of the power line independent from the switching conditions of the power networks. Standard DP Selta tuning devices of the wideband type are more common:

- Single frequency and double frequency tuning devices are available upon request.

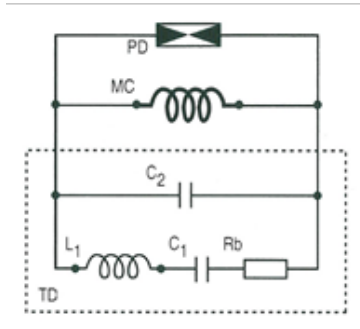

Circuit diagram of a band tuned line trap:

MC = Main Coil

PD = Protective Device

TD = Tuning Device

MAIN COIL

The main coil consists of one or more cylindrical windings—depending on the value of the nominal current—, concentrically located and electrically connected in parallel.

Each winding consists of an aluminium alloy section bar with a rectangular cross-section and with the shortest side parallel to the line trap axis, to guarantee high mechanical strength.

The turns are adequately separated from each other, to improve cooling and high frequency properties: the separators are made of impregnated sturdy fibres providing high insulation and mechanical strength.

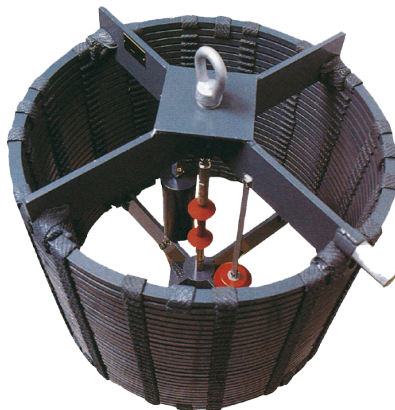

MOUNTING

• SUSPENSION

All the line traps are equipped with an eye bolt fixed on the top spider having the following characteristics:

Line Trap weight Kg	Tensile strenght Kg	Height (h") mm	Eye Diam. mm
Ws240	1000	160	50
250≤Ws390	1600	200	60
400≤Ws750	2500	220	70

• PEDESTAL

For pedestal mounting directly onto coupling capacitors, capacitors voltage transformers or station post insulators, the line traps are equipped with a pedestal made of antimagnetic material and electrically connected to the lower terminal. The pedestals have adequate heights to prevent excessive heating of the coupling capacitor/CVT or post insulators fittings due to the magnetic field of the main coil. Standard height (h") is 200 mm. Different pedestals heights and templates are available upon request to suit customer requirements.



TECHNICAL FEATURES

- LN Rated inductance of the main coil.
- IN Rated continuous current.
- IKN Short time current (1 sec.).
- IKm Asymmetrical peak value (2,55 IKN)
- U Surge arrester continuous service voltage.
- U' Surge arrester short time applicable voltage.

(* Other models can be designed on demand.

IEC (50Hz)			L _N = 0.2mH					L _N = 0.5mH				
I _N	I _{KN}	I _{KM}	Type	U/U'	Φ	H	Weight	Type	U/U'	Φ	H	Poids
(A)	(kA)	(kA)	SBSN	(KV _{ms})	(mm)	(mm)	(Kg)	SBSN	(KV _{ms})	(mm)	(mm)	(Kg)
630	20	51	630/0.2	3/3.4	506	657	65	630/0.5	3/3.4	726	777	107
800	25	64	800/0.2	3/3.4	606	696	62	800/0.5	6/6.8	870	821	132
1250	40	102	1250/0.2	3/3.4	840	590	133	1250/0.5	6/6.8	1250	1453	372
2000	40	102						2000/0.5	6/6.8	1270	1407	430
2000	50	127.5	2000/0.2	3/3.4	1090	917	239					
2500	40	102						2500/0.5	6/6.8	1290	1458	530
3150	50	127.5	3150/0.2	3/3.4	1270	1349	393					
4000	63	161	4000/0.2	6/6.8	1480	1322	540					

CONNECTIONS

Connections are suitable for the construction of medium and large capacity systems, both for basic and expandable equipment, and for the redundancy characteristics.

Standard cylindrical shape
(for line traps up to IN

<=1250)



Standard rectangular shape
(for line traps with IN>1250)

The two terminals are welded on one arm of the top and bottom spiders and have radial orientation at 180°.